

The Effect of Technology Investments on Hospital Budget and Patient Safety: A Simulation for Emergency Department.

Onur Deryahanoglu, Batuhan Kocaoglu

Abstract: *One of the most important problems for hospital management is long waiting times. Especially in Emergency Departments, which are very crowded in terms of the number of applicants, patients wait for a long time without any treatment. Long waiting times between stations affect the total length of stay of the patients in this department. In this case, it directly affects patient safety. Furthermore, patients can leave from hospitals because of not to take effective and rapid treatment or lack of resource. Patient satisfaction is negatively affected and the brand value of these hospitals may decrease. All these events trigger hospital budget also. Hospital managers who faced these problems before, should first review all their existing processes, identify roadmaps and plan improvements. They are able to make use of advanced technologies and make investment decisions for improvement processes. However, investment decisions can be quite costly and can effect of hospital budget economically. Therefore, the use of simulations to compare the results of investment decisions can provide much more accurate decisions. The purpose of this study is to support hospital managers in making decisions by monitoring the impact of investment decisions (technology or resource investment) on the hospital budget. Both investment decisions will be simulated comparatively, patient processes and resource planning will be improved by creating a sustainable management model with RFID Technology.*

Keywords : *RFID, Simulation, Healthcare, Technology and Resource Planning*

I. INTRODUCTION

Patient safety is one of the factors in the state of quality of health services and is considered a priority in healthcare [1]. Besides, overcrowding in Emergency Departments is a problem worldwide and affects the ability to provide emergency medical care within a reasonable period of time. The number of patients who present in emergency departments is growing and the department ability to assist patients with acute complains is constant. Delays in the ED may cause dramatic outcomes for patients. ED's performance in terms of patients flow and of the available resources can be studied using the Queuing Theory [2].

Long waiting times and long staying times are also among the factors that directly affect the satisfaction of the patients. They can leave the hospital without any payment or treatment. At this point, hospital managements need to use various

technologies and plan improvements to manage these processes correctly.

Technology adoption and information technology in particular, have been linked to productivity growth in a wide variety of sectors [3]. It is thought that the use of information technologies, especially in health sector and hospitals, will directly increase the quality of treatment and care processes and patient satisfaction. Hospitals have high educated and equipped employees are available so time and resource management should be well planned. It is very important to create simplify and sustain processes as management philosophy.

As well as the balance between the human and physical resources, it is also essential to maintain an appropriate mix between the different types of health promoters and caregivers to ensure the system's success . Due to their obvious and important differences, it is imperative that human capital is handled and managed very differently from physical capital. The relationship between human resources and health care is very complex, and it merits further examination and study [4].

The ability of a healthcare system to provide safe, high quality, effective, patient centered services depends on sufficient well motivated and appropriately skilled personnel operating within service delivery models that optimize their performance. The policies and methods used to manage human resources are at the core of any sustainable solution to healthcare system performance and can constrain or facilitate healthcare sector reform [5]. Hospitals have many different and tough mechanism and equipped with high-end technologies. In this complexity doctors, nurses or other health professions must work together in harmony. In these reasons, making immediate and accurate decisions in terms of patient care and safety is extremely important for hospital management. At this point, hospital managements or investors should turn to the right technologies in terms of patient satisfaction and safety, encourage their employees to use modern technologies and analyze the results of investment decisions.

Designing hospitals with using advance technologies (RFID, Hospital Information System, Supply Chain Management System, Warehouse Management System, Drug Management System) reduce the workload of the employees and increase their productivity and safety also. In addition, they have effective reporting structure so it will accelerate hospital managers make operational and strategic decisions.

From the perspective of the provider, the general model of a

Revised Manuscript Received on August 20, 2019.

Onur Deryahanoglu, Logistic and Supply Chain Management, Maltepe University, Istanbul, Turkey, onur.deryahan@gmail.com

Batuhan Kocaoglu, Management Information Systems, Piri Reis University, Istanbul, Turkey, batuhan.kocaoglu@gmail.com

The Effect of Technology Investments on Hospital Budget and Patient Safety : A Simulation for Emergency Department

firm's IT investment objectives of increased profitability, most likely through efficiency gains, and productivity, can apply to hospitals. For example, if IT can lower the cost of treating a hospitalized patient for the same reimbursement price through prospective payment, a more profitable admission will result. The preceding example illustrates the cost-minimizing side of improving profitability. If hospitals IT investments have met their objectives, then future calls for expensive IT investments will be far more compelling and sustainable over time [6].

Besides, the costs of technology investments are quite high. Hospital managers can prioritize investment decisions. For instance, Emergency Departments need improvement processes and real time tracking in terms of patient density and complexity more than other departments. They are the center for treating patients with accident injuries and/or acute sicknesses of different levels of medical needs on a daily basis that the patients must receive the most adequate treatment and care in the shortest possible time from both the physicians and the nurses. Upon the arrival at an emergency room a patient goes through a medical operation procedure, including triage, registration, treatment, cashier, pharmacy, and admission, which require seamless collaboration with the medical treatment team [7].

In this study, an Emergency Department will simulate which located in Turkey. Patient processes and resource planning will redesign. The impact of investment decisions (technology or resource) on the hospital budget and will be focused. The simulation models of the Emergency Department will be simulated with using RFID Technology and it will be aimed to support hospital managers in the investment decision process. It is also aimed to improve patient safety and patient satisfaction.

II. MATERIALS AND METHODS

A. Arena Simulation Software

Arena is a discrete event simulation and automation software developed by Systems Modeling and acquired by Rockwell Automation in 2000. In Arena, the user builds an experiment model by placing modules (boxes of different shapes) that represent processes or logic. Connector lines are used to join these modules together and to specify the flow of entities. While modules have specific actions relative to entities, flow, and timing, the precise representation of each module and entity relative to real-life objects is subject to the modeler. Statistical data, such as cycle time and work in process levels, can be recorded and made output as reports. Rockwell Arena 14. version is used in this study.

Simulations are primarily concerned with experimentally predicting the behavior of a real system for the purposes of designing or modifying its behavior to achieve a certain purpose or solve a particular problem. Depending on the simulation results, attempting additional runs on the experiments may be ideal and this can be achieved by changing factors such as parameters, variables, decision rules, starting conditions and run length [8]. Simulations can be successfully applied in many industries such as *banking, manufacturing, hospital, supply chain* to assess the existing situation and the consequences of possible scenarios. In this

way, investors, analysts or managers can refer to making sustainable and right decisions about their companies.

B. RFID Technology

Radio Frequency Identification (RFID) Technology uses electromagnetic fields to automatically identify and track tags attached to objects. The tags contain electronically stored information. Passive tags collect energy from a nearby RFID reader's interrogating radio waves. Active tags have a local power source (such as a battery) and may operate hundreds of meters from the RFID reader.

Today, various RFID applications are used safely in many sectors such as *retailing, storage, health, security, inventory management, human resources*. In this way, employee productivity increases and process problems are eliminated. Especially in hospitals, it is very important to implement this technology because of their different and complex structures. In the past decade, the risk of harm caused by medical care has received increasing scrutiny. The growing sophistication of computers and software should allow information technology to play a vital part in reducing that risk by streamlining care, catching and correcting errors, assisting with decisions, and providing feedback on performance. [9].

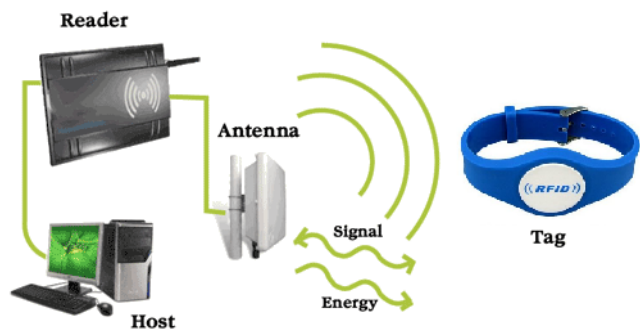

Figure 1 : RFID Enabled Technology Design in Hospitals

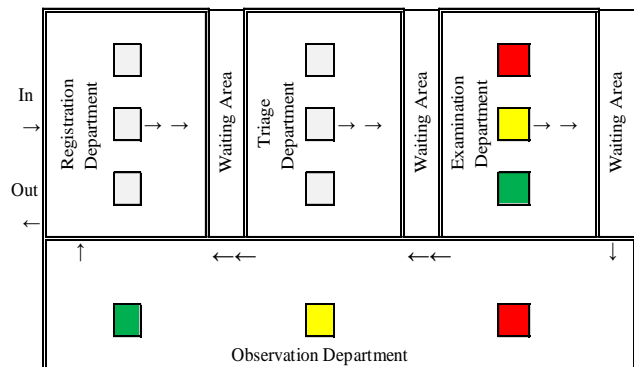

Figure 2 : Patient Flows in Emergency Department

Table 1 : Projected RFID Technology Costs

	Unit Price (USD)	Planned Quantity	Total (USD)
UHF RFID Reader	4000	18	72
UHF RFID Wristband	50	1000	50
UHF RFID Antenna	4000	18	72
Computer & Software & Installation	15000	18	270
Total Cost			464000

In this study, a real time patient tracking system will be established by using RFID technology into the Emergency Department simulation model. In this way, the patient density will be analyzed and the optimum number of employees will be determined.

C. Data Analysis

It will be simulated of an Emergency Department (a public hospital in Turkey) in this study. The duration of all process between stations (registration, triage, examination and observation) and mean waiting times of the patients will be analyzed. Total length of stays in Emergency Department and utilizations will be seen. A 24-hour database was created as a result of the Hospital Information and Management System, the measurements taken from the observations and face-to-face interviews with the department’s professionals. In this way, the existing structure and improvement processes of the system (total waiting times, total staying times, optimum number of employees, or leaving the hospital without payment or without any excuse) will be planned. In addition, hourly/monthly/yearly costs of Emergency Service resources (doctors, nurses, registration staffs) will be analyzed. In this way, it supports to hospital managers which decision (technology or resource investment) will be the best. Hospital managers will evaluate the results of both investment decisions and observe their contributions to hospital budget. In this database, there are lots of information such as time of arrival to the Emergency Department, duration of the processes in registration, duration of the processes in triage, level of triage, duration of processes in examination and duration of residence in observation room (24 hour basis). In addition, it will be occurred waiting times between stations as a result of simulations.

Table 2 : Existing Database of Emergency Department

Patient	Patient Arrival Time	Registration Department Process Time	Triage Department Process Time	Triage Level	Examination Department Process Time	Observation Department Occupancy Time
1	8:00:24	0:00:55	0:03:45	1	0:12:00	2:05:02
2	8:01:53	0:00:54	0:03:00	2	0:09:45	1:35:06
3	8:01:57	0:00:48	0:03:00	3	0:10:00	1:39:13

Table 3 : Number and Cost of Resources

	Number of Existing Resources	Cost of Resource (Hour/USD)
Doctor	7	36.6
Triage Nurse	3	25.5
Observation Nurse	9	25.5
Registration Staff	2	11.1
Patient Bed	60	0

C.I. Data Analysis of Registration Department and Design with Arena Simulation Program

The Department of Registration is the area where patient’s identity information is entered into the Hospital Information and Management System by the registration staff at the entrance of the Emergency Department. Patients who are with critical conditions (such as traffic accident, heart attack, injury) as a result of an ambulance or visual examination their triage is determined as Level 1 (Red Code) are directed directly to the Medical Examination Department in order not to lose time. However, registration procedures are completed by patient’s companion for this patient. Therefore, a dummy patient companion has added to the program. Statistical distribution analysis has performed as using Arena Input Analyzer Program according to database (in seconds). As a result of this analysis, it was seen that the registration staffs processing times belonged to *Beta Distribution* (Chi-Square Test p-value = 0,357 > 0,05). *Simulation 1*; The number of resources, costs of resources and the processing times are defined to the Arena Simulation Program according to the statistical data analysis obtained from database. Through this simulation, the existing workflow, all cost (busy/idle) of resources and waiting times of the department will be evaluated and then improvement works will be planned. *Simulation 2*; After registration is completed, an *RFID Wristband* which works with *Active Tag Technology*, is attached to the patient's arm. Thus, real time patient tracking is provided in each station.

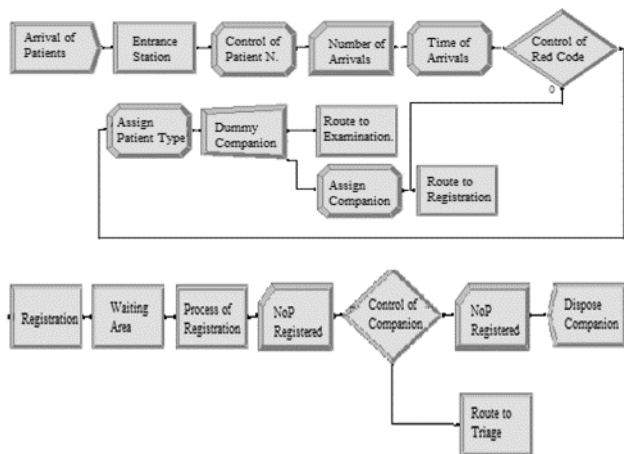

Figure 3 : Arena Model of Registration Department

Time of patient arrivals in Emergency Department is another important issue. In this direction, statistical distribution analysis has performed as using MS Excel Program according to database (in minutes). As a result of this analysis, it was seen that arrival times of patients belonged to *Poisson Distribution* (Chi-Square Test p-value=0,44 > 0,05). There is a link between the Poisson Distribution and Exponential Distribution. In this way, time between two patients; EXPO (1/α) : 1/0,65988 : 1,515 (in minutes).

C.II. Data Analysis of Triage Department and Design with Arena Simulation Program

The priority levels (1-Red Code, 2-Yellow Code, 3-Green Code) of the patients are determined according to their urgency status in Triage Departments.

The Effect of Technology Investments on Hospital Budget and Patient Safety : A Simulation for Emergency Department

Patients are directed to there after the patient information is entered into the system. In this area, Triage Nurses follow the vital signs (pulse, blood pressure, fever, diabetes level) of patients and evaluate their past stories and make prioritization. Statistical distribution analysis has performed as using Arena Input Analyzer Program according to database (in seconds). As a result of this analysis, it was seen that the triage nurses processing times belonged to *Weibull Distribution* (Chi-Square Test $p\text{-value} = 0,396 > 0,05$). *Simulation 1*; The number of resources, costs of resources and the processing times are defined to the Arena Simulation Program according to the statistical data analysis obtained from database. Through this simulation, the existing workflow, all cost (busy/idle) of resources and waiting times of the department will be evaluated and then improvement works will be planned. *Simulation 2*; This area has been designed with RFID Enabled Technology and integrated into Arena Simulation Program as follows: A signal is generated every minute to measure the intensity of the patient queue with *Create Module*. After, the condition in the queue is checked with *Decide Module*. If the average waiting time of the patients in the Triage Department exceeds 15 minutes, increasing the number of Triage Nurses + 1 (min: 2 existing resource - max: 4 with variable resource), to reduce average waiting times. If the average waiting time exceeds 15 minutes, RFID Technology sends an alarm signal to the to the Management Center, so it provides real time monitoring. Then, the management center evaluates the processes for reducing average waiting intensity and they assign +1 Triage Nurse within *UNIF Distribution* (1,5) minutes.

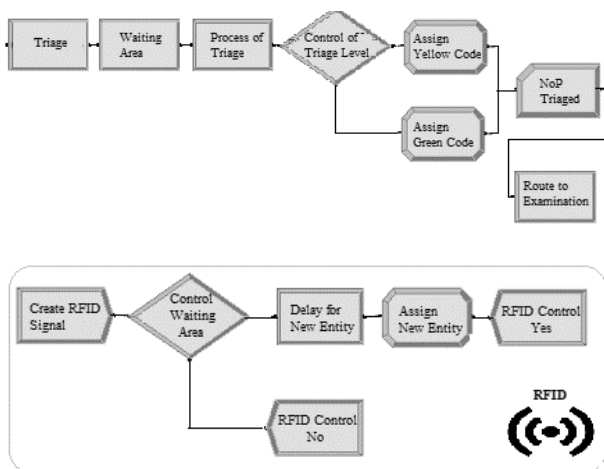

Figure 4 : Arena Model of Triage Department

C.III. Data Analysis of Examination Department and Design with Arena Simulation Program

Medical examinations are performed according to patients triage levels in Examination Department. In this way, patients are diagnosed and treatment plans are established. Statistical distribution analysis has performed as using Arena Input Analyzer Program according to database (in minutes). As a result of this analysis, it was observed that doctor processing times could not be used for simulation model because Chi Square Test was not positive ($p\text{-value} < 0.05$). In this case, if a data set does not fit to any known standard distribution, an *Empirical Distribution* can be generated. So doctors processing times generated by this distribution and defined to the Arena Simulation Program such as : CONT (0.000, 8.210,

0.000, 8.505, ...). *Simulation 1*; The number of resources, costs of resources and the processing times are defined to the Arena Simulation Program according to the statistical data analysis obtained from database. Through this simulation, the existing workflow, all cost (busy/idle) of resources and waiting times of the department will be evaluated and then improvement works will be planned. *Simulation 2*; This area has been designed with RFID Enabled Technology and integrated into Arena Simulation Program as follows: A signal is generated every minute to measure the intensity of the patient queue with *Create Module*. After, the condition in the queue is checked with *Decide Module*. If the average waiting time of the patients in the Examination Department exceeds 10 minutes, increasing the number of Doctors + 1 (min: 7 existing resource - max: 9 with variable resource), to reduce average waiting times. If the average waiting time exceeds 10 minutes, RFID Technology sends an alarm signal to the to the Management Center, so it provides real time monitoring. Then, the management center evaluates the processes for reducing average waiting intensity and they assign +1 Doctor within *UNIF Distribution* (1,5) minutes.

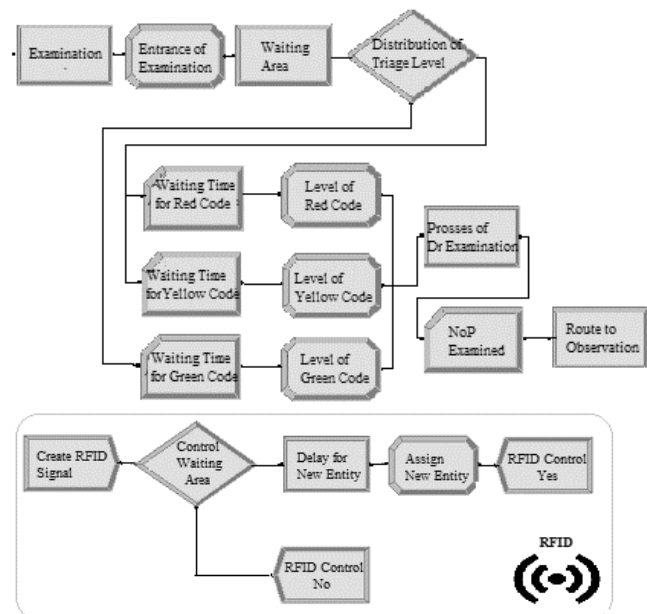

Figure 5 : Arena Model of Examination Department

C.IV. Data Analysis of Observation Department and Design with Arena Simulation Program

A short-term care of patients according to treatment plans are performed in Observation Departments. Patients who have level of Red Codes, are prioritized in the waiting area. Observation Nurses start to perform the first controls *immediately* which determined by the doctors for this patient. It can take *30 minutes* for level of Yellow or Green Codes. Statistical distribution analysis has performed as using Arena Input Analyzer Program according to database (in minutes). As a result of this analysis, it was seen that the observation nurses processing times belonged to *Normal Distribution* (Chi-Square Test $p\text{-value} = 0,07 > 0,05$).

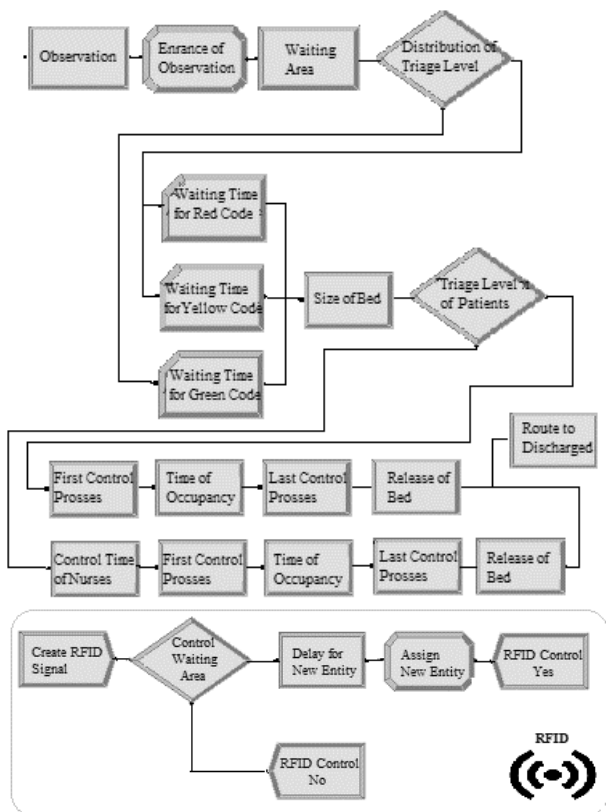

Figure 6 : Arena Model of Observation Department

Simulation 1; The number of resources, costs of resources and the processing times are defined to the Arena Simulation Program according to the statistical data analysis obtained from database. Through this simulation, the existing workflow, all cost (busy/idle) of resources and waiting times of the department will be evaluated and then improvement works will be planned. *Simulation 2*; This area has been designed with RFID Enabled Technology and integrated into Arena Simulation Program as follows: A signal is generated every minute to measure the intensity of the patient queue with *Create Module*. After, the condition in the queue is checked with *Decide Module*. If the average waiting time of the patients in the Examination Department exceeds 5 minutes, increasing the number of Observation Nurse + 1 (min: 9 existing resource - max: 13 with variable resource), to reduce average waiting times. If the average waiting time exceeds 5 minutes, RFID Technology sends an alarm signal to the to the Management Center, so it provides real time monitoring. Then, the management center evaluates the processes for reducing average waiting intensity and they assign +1 Observation Nurse within *UNIF Distribution (1,5)* minutes. So, it is prevented that patient's long term waiting without any treatment.

III. RESULTS

The simulations of the Emergency Department (*Simulation-1: Existing Model and Simulation-2: RFID Enabled Model*) have been realized with the Arena Simulation Program according to the existing 24-hour database. They were repeated 1000 times in terms of the accuracy and reliability of the information. Detailed analysis of the simulations is listed below:

A. Number of Patients : The results of simulations are given below for number of patients

Table 5 : Comparison of Number of Patients

	Results of Simulation-1 (Existing Model)	Results of Simulation-2 (RFID Enabled Model)	Improvement Rate
Number of Patient Arrivals	952	950	-0.21%
Number of Patient Registered	951	949	-21%
Number of Patient Triage	926	935	0.97%
Number of Patient Examined	802	796	-0.75%
Number of Patient Discharged	602	830	37.87%
Number of Patient without Payment	9	0	-100%

The number of patients who had completed the discharge procedure was improved by 37.87 %. Besides, patients who left from hospital without any payment was prevented by 100 % because of RFID Technology.

B. Utilizations : The results of simulations are given below for capacity of utilizations.

Table 6 : Comparison of Resource Utilizations

	Results of Simulation-1 (Existing Model)		Results of Simulation-2 (RFID Enabled Model)		
	Number of Existing Resources	Utilization Rate	Number of Resources	Variable Resources	Utilization Rate
Doctor	7	0.96	7	2	0.91
Triage Nurse	3	0.97	2	2	0.86
Observation Nurse	9	0.64	9	4	0.87
Registration Staff	2	0.34	2	0	0.34
Patient Bed	60	0.95	60	0	0.86

Utilizations were so high in existing model. According to the average waiting times of the patients, variable resources are assigned to the stations because of RFID System. Therefore, resources were started to use more efficient.

C. Cost of Resources : The results of simulations are given below for cost of resources (doctors, nurses or registration staffs).

Table 7 : Comparison of Resource Costs

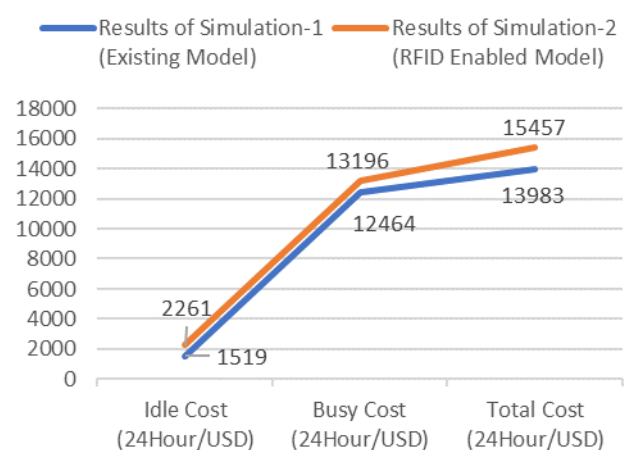

According to the results of simulations, RFID Technology (with variable resources) impacts 9.54% (or 1474 USD) on hospital budget (24 hour based).

The Effect of Technology Investments on Hospital Budget and Patient Safety : A Simulation for Emergency Department

D. Return of Investment (ROI) : The results of simulations are given below for return of investment.

Table 8 : Total Incomes of RFID Technology Investment

	Benefits of RFID Technology (USD)	Patient Payment (USD)	Daily Income (USD)	Monthly Income (USD)	Yearly Income (USD)	2-Year Income (USD)
Number of Patient Discharged	228	10	2280	68400	820800	1641600
Number of Patient w/o Payment	9	10	90	2700	64800	129600
						Total Income 1771200

Table 9 : Total Costs of RFID Technology Investment

	Daily Cost (USD)	Monthly Cost (USD)	Yearly Cost (USD)	2-Year Cost (USD)
Cost of Investment RFID Technology	0	0	0	464000
Cost of Variable Resources	1474	44220	530640	1061280
				Total Cost 1525280

With RFID Technology, 228 more patients were discharged and 9 patients were prevented from leaving hospital without any payment (according to existing model). Thus, it was observed that RFID Technology investment would provide 16.12% additional income to hospital budget (at the end of 2 years).

$$ROI = \frac{\text{Total Income} - \text{Total Cost}}{\text{Total Cost}}$$

$$ROI = \frac{1771200 - 1525280}{1525280} = 16.12\%$$

E. Net Present Value (NPV) : The results of simulations are given below for RFID Technology Investment of NPV.

Table 10 : Total Incomes of RFID Technology Investment

Year	Benefits of RFID Technology (USD)	Patient Payment	Cost of Capital	NPV (USD)
1	853200	10%	4.27%	816738
2	938520	10%	4.27%	898412
3	1032372	10%	4.27%	988254
4	1135609	10%	4.27%	1087079
5	1249170	10%	4.27%	1195787
				Total Income 4986270

As a result of the values obtained in the above 5-year table, the net present value of the total incomes from RFID Technology Investment is 4.986,270 USD. Patient payments are expected to increase 10% for every year and when calculating of discount value, the annual interest rate is assumed to be 22% (averages of 5 years) and the annual inflation rate is assumed to be 17% (averages of 5 years).

$$i = \frac{(1 + 0.22)}{(1 + 0.17)} - 1 = 0.0427 = 4.27\%$$

Table 11 : Total Costs of RFID Technology Investment

Year	Cost of Variable Resources (USD)	Salary	Cost of Capital	NPV (USD)	Cost of RFID Technology Investment (USD)
1	530640	10%	4.27%	507963	464000
2	583704	10%	4.27%	558759	0
3	642074	10%	4.27%	614635	0
4	706282	10%	4.27%	676099	0
5	776910	10%	4.27%	743709	0
				3101165	464000
				Total Cost	3565165

As a result of the values obtained in the above 5-year table, the net present value of the total costs from RFID Technology Investment is 3.565,165 USD. It is assumed that the salaries of resources (doctors, nurses or registration staffs) will

increase by 10% on average each year, while the capital cost (discount value) is assumed to be 4.27% on average annually. It was seen that RFID Technology investment would provide 1.421,105 USD additional income to hospital budget according to NPV.

$$NPV = \text{Total Incomes} - \text{Total Costs}$$

$$NPV = 4.986,70 - 3.565,165 = 1.421,105 \text{ USD}$$

IV. ONCLUSIONS AND FUTURE DISCUSSIONS

Simulations were performed with *Arena Simulation Program* over the database of the Emergency Department. Accordingly, *Simulation : 1* was created to take a picture of the existing state of the department. *Simulation : 2* is the model where RFID Technology is adapted and variable resources are included in the processes according to patient density. In both cases, it aims to give an idea of investment decisions by comparing their impact on hospital budgets.

According to the comparison of simulations results, RFID Technology increased the number of patients (from 602 to 830) discharged by 37.87%. Besides, 9 patients who left from hospital without any payment was prevented. (If the patients leave from hospital without payment, the RFID System sends a warning signal to the management center and the patients exits are blocked at the exit of the department.) In these ways, it will contribute positively to the overall budget of the hospital.

The average waiting times between stations (registration, triage, examination and observation) was reduced from 44.2 minutes to 15.31 minutes. Accordingly, the total length of stay times was decreased from an average of 269.17 minutes to 160.86 minutes. In this case, patients can take faster and more effective treatment, so patient satisfaction will directly increase.

When making investment decisions, the break-even point should be as short as possible. In the return of investment analysis, it was seen that RFID Technology investment would provide 16.12% additional income to the hospital budget at the end of 2 years.. It means, an investment that makes the company profit is considered to be quite successful at the end of 2 years.

In net present value method for capital budgeting to evaluate the profitability of proposed investments and projects, RFID Technology investment showed that it would provide 1.421.105 USD additional income to the hospital budget at the end of 5 years.

One of the most important factors affecting costs to design variable resources management model. In this way, according to the average of patient density (RFID Technology controls to patient density and hospital managers can track them in real time), variable resources (such as doctors or nurses) working in other parts of the hospital will be able to log into the stations. Also, they exit from the stations when the average of waiting densities decreases. Thus, resource utilizations and costs will be optimal and there will be no need to permanently allocate new employees and costs.

Besides all these benefits of RFID Technologies can adapt to other departments of hospitals for maximum efficiency in near future. For instance, overall supply chain expenditures can reduce because of real time asset tracking model. Security



problems can be largely prevented.

Data quality can improve and managers make better decisions for hospital processes. It can contribute financially to hospital budget due to more efficient employees. For these reasons, hospital managers and investors should be able to benefit from the advantages of advanced technologies and be able to encourage their employees.

REFERENCES

1. María Pérez, M. C. (2012). Application of RFID Technology in Patient Tracking and Medication Traceability in Emergency Care. *J Med Syst*, 3983-3993.
2. Hajnal Vassa, Z. S. (2015). Application of Queuing Model to Patient Flow in Emergency Department : Case Study. *Procedia Economics and Finance*, 479- 487.
3. Agha, L. (2014). The Effects of Health Information Technology on the Costs and Quality of Medical Care. *J Health Econ.*, 19-30.
4. Stefane Kabene, C. O. (2006). The importance of human resources management in health care : A global context. *Human Resources for Health*, 4-20.
5. Brigita Skela Savič, A. R. (2013). Capacity of middle management in healthcare organizations for working with people : The case of Slovenian hospitals. *Human Resources for Health*, 11-18.
6. Stephen Parente, L. V. (2006). Valuing Hospital Investment in Information Technology : Does Governance Make a Difference? *Health Care Financing Review*, 31-43.
7. J. Enciso, J. V. (2016). Modeling and Simulation of Passenger Traffic in a National Airport. *14th LACCEI International Multi-Conference for Engineering, Education and Technology*. San Jose, Costa Rica: Engineering Innovations for Global Sustainability.
8. Wilson Nyembaa, C. M. (2016). Modelling, simulation and optimization of the materials flow of a multi-product assembling plant. *14th Global Conference on Sustainable Manufacturing* (pp. 59-66). Stellenbosch, South Africa : Elsevier.
9. Sima Ajami, A. R. (2013). Radio Frequency Identification (RFID) technology and patient safety. *Journal of Research in Medical Sciences*, 809-813.

AUTHOR PROFILE



Onur Deryahanoglu received his education in different fields. Biomedical Engineering (BSc), Hospital and Healthcare Management (MSc) and Logistic and Supply Chain Management (PhD). He has more than 13 years of professional experience working as Biomedical Systems Manager, Project Manager and Operation Manager in healthcare sector. He has also consulting experience in Biomedical Engineering, Medical Device & Technology Investments, Hospital Planning & Design and Facility & Risk Management. He is currently working as a Project Manager in one of the global-leading healthcare company.



Batuhan Kocaoglu received his BSc, MSc, Ph.D. in Industrial Engineering. He has worked for more than 15 years as a Production Planning Manager and ERP Project Manager. He has consulting experience in SCOR processes, software selection, reporting needs analysis, SME projects, and MRP check-up. His main research areas are digital transformation, Industry 4.0 readiness, ERP, MRP, production planning, S&OP, and SCM. He has taught courses production inventory management, ERP, MIS, logistics information systems, supply chain design in Poznan Economics, Montenegro, Maltepe and Okan Universities. He is currently working as the Head of Management Information Systems Department at Piri Reis University